

Stretch wrapping machine LS

short info short info short info short info short info

- ▶ *automatic wrapping cycle with 3 wrapping modes (single, cross, rain proof)*
- ▶ *film carriage inside of the column, all moving parts covered inside of the machine*
- ▶ *stringsystem to wrap pallets for automatic storage*
- ▶ *change of film roll in ergonomic height*
- ▶ *fasten of the film is possible in ergonomic height*



LENG
Stretch

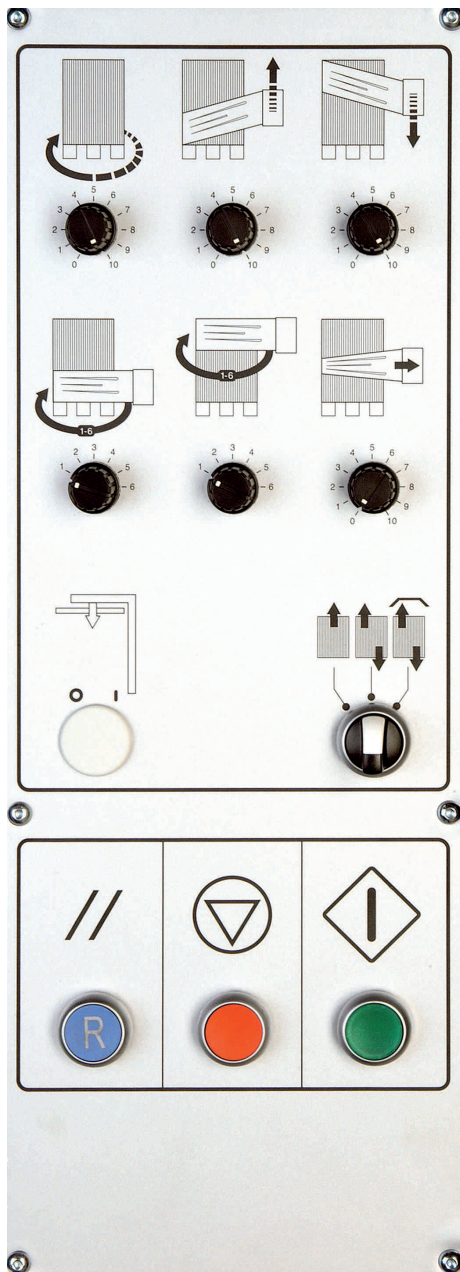

Standard equipment

- 3 different wrapping modes
- adjustable speed of the turntable (3 - 12 RPM)
- adjustable speed of the carriage (0,7 - 4 m/Min) different for up and down
- soft-start and -stop by inverter
- fixed stop of the turntable
- adjustable numbers for bottom and top wrapping rounds (1 - 6 turns)
- adjustable overlapping of the film
- adjustable overlapping at the top of the pallet
- photocell for pallet height detection
- simple and self-explaining symbols
- simple to operate
- strong and servicing friendly construction
- power control lamp
- Stop-button to interrupt the wrapping cycle
- Door to open the film carriage, easy to change the film



Technical data

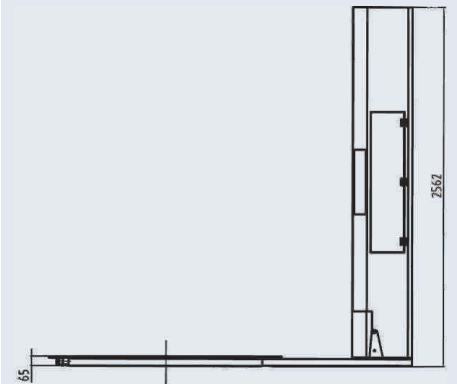

length	2.575 mm
width	1.650 mm
height of turntable	65 mm
turntable Ø	1.650 mm
height of column	2.562 mm
height ofmaschine	2.582 mm (LS 200)
	2.652 mm (LS 300)
weight	520 kg
voltage	230 V, 1 Ph, 50 Hz

Dimension of the load pallet

length max.	1.200 mm
width max.	1.100 mm
height max.	2.400 mm
weight max.	2.000 kg

Technical equipment

pockets to move and handle the machine by fork lift truck (columnside + turntable side)
 PLC-control
 Inverter with EMC-filter, A-class
 CE-sign

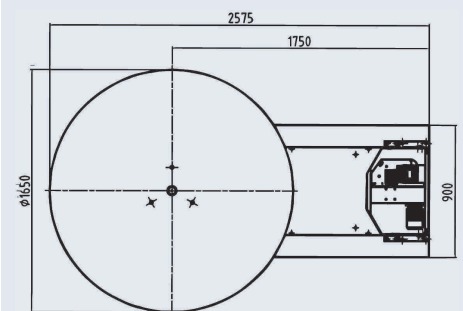

Technical specifications may vary without prior notice

Versions

LS 200 LT - fitted with electromagnetic brake for film tension

LS 300 LT - fitted with motorized Prestretchsystem for film tension up to 290%

Options / Equipment

ramps

pit frames for floor embedding the machine to use without ramp

manual top sheet dispenser